

50210322P0

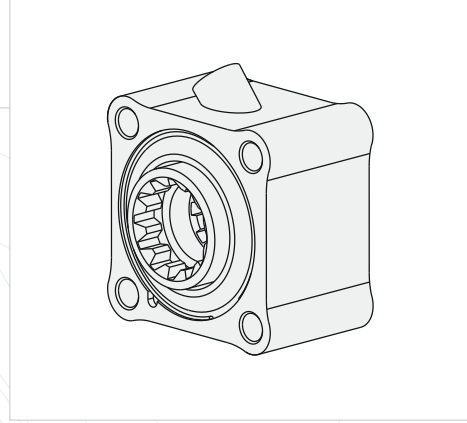

AIR INLET R 1/4"
HAVA GİRİŞİ R 1/4"

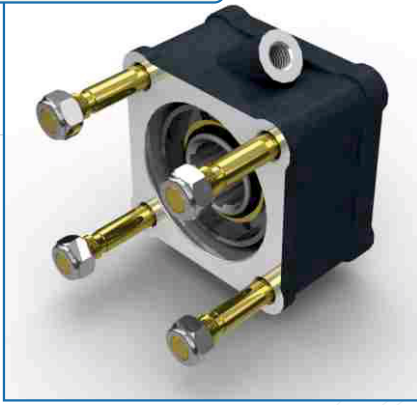
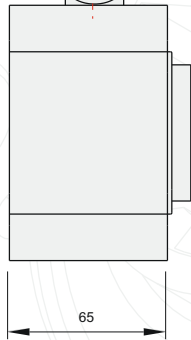

DIN 5462 8x32x35

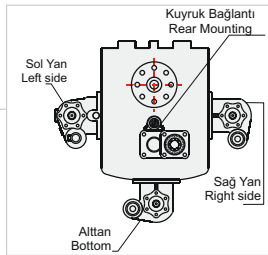
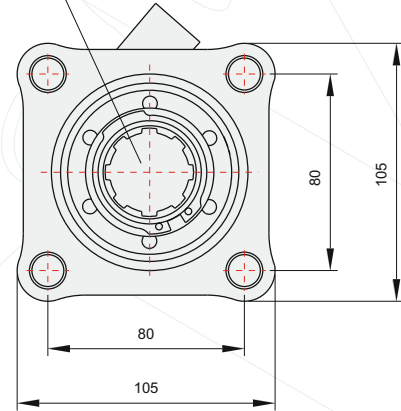

GENEL BİLGİLER/GENERAL DATA

P.T.O. KODU / P.T.O. CODE	50210322P0	
Tork / Torque	48,9 Kgm	479,5 Nm
Güç(1000 rpm) / Power	34,5 Hp	25,7 Kw
Devir / Speed	513 rpm	513 rpm
Oran / Ratio	1/1	1/1
Ağırlık / Weight	7 kg	15,4 lb
Bağlantı / Mounting	Kuyruk	Rear
Kumanda / Control	Havalı	Pneumatic
Dönüş / P.T.O. Rotation	Sağ - ISO	Right - ISO

Ana Şanzıman / Gearbox	Kullanılan Bazı Araçlar / Used Vehicles
ZF16S251-221-151-150-130- ZF S5/AK/65-120-111-110-92- GP ZF S5/AK/6S-90-80-70-66- 65-55-50-42-36-35-ZF-ECOMIT 9S75-9S109-16S109 ZF NEW ECOSPLIT 16S1620TD- 16S1820TO-18S1820TO- 16S2220TD-16S220TO- 16S2520TO- 16S2023TDL	MAN / MERCEDES / BMC PROFESYONEL / FORD CARGO / CHRYSLER HINO / DODGE / FARGO / IVECO / DAF/ DAEWOO / RENAULT

Seçeğinizin pompanın dönüş yönü, P.T.O. dönüş yönü ile ters olmalıdır.
The rotation of the chosen pump has to be opposite with the rotation of P.T.O.

P.T.O. montaj edildikten sonra ana şanzıman yağını tamamlayın.
Fill the oil of the gear box after mounting the P.T.O.