

50220512P0

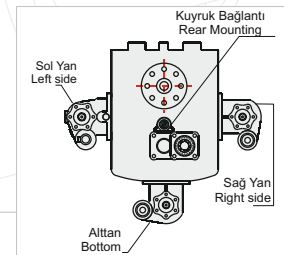
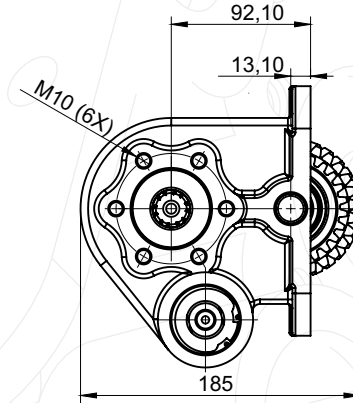
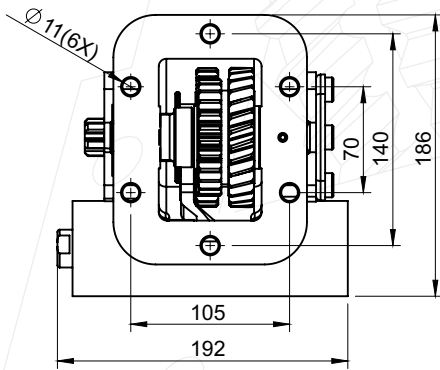
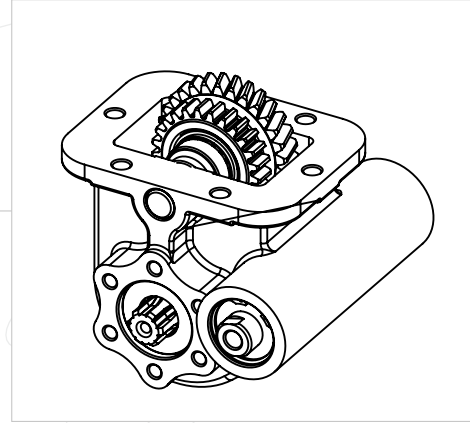

GENEL BİLGİLER/GENERAL DATA

P.T.O. KODU / P.T.O. CODE	50220512P0	
Tork / Torque		300 Nm
Güç(1000 rpm) / Power		32 Kw
Devir / Speed	650 rpm	650 rpm
Oran / Ratio	1/1,2	1/1,2
Ağırlık / Weight	14,1 kg	31 lb
Bağlantı / Mounting	Sağ	Right
Kumanda / Control	Pnömatik	Pneumatic
Dönüş / P.T.O. Rotation	Sol - UNI	Left - UNI

Ana Şanzıman / Gearbox
ZF ECOLITE S5-42 (5,72)

Kullanılan Bazı Araçlar / Used Vehicles
8.150-8.153-10.153-10.163-10.185 MAN / MB 800-1215-1517 ATEGO MERCEDES-BENZ / 45LF-170 DAF / NISSAN ATLEON / 45.120-130-150-160-50.130 LEYLAND DAF / RENAULT 120.07-S 120.08-135-370 MIDLUM / BADSAN IRAN302-304-306-313-317 LEYLAND / 45LF.150-45LF.170 / MERCEDES VARIO-LEICHT 614-712-715-812-814-815

Seçeğiniz pompanın dönüş yönü, P.T.O. dönüş yönü ile ters olmalıdır.
The rotation of the chosen pump has to be opposite with the rotation of P.T.O.

P.T.O. montaj edildikten sonra ana şanzıman yağını tamamlayın.
Fill the oil of the gear box after mounting the P.T.O.