

50126322

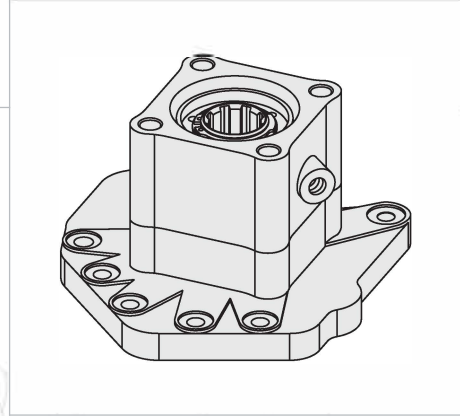

AIR INLET R 1/4"
HAVA GİRİŞİ R 1/4"

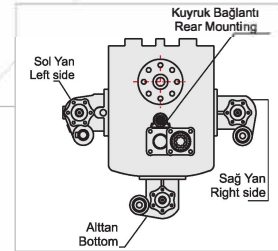
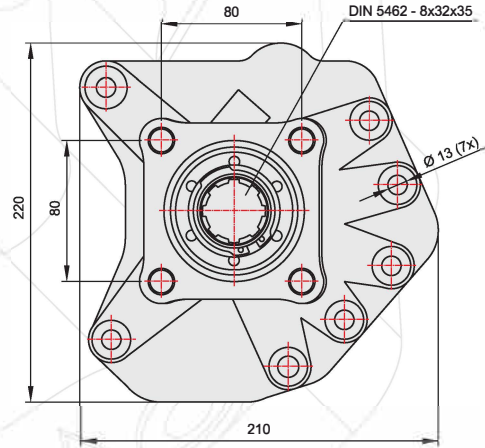
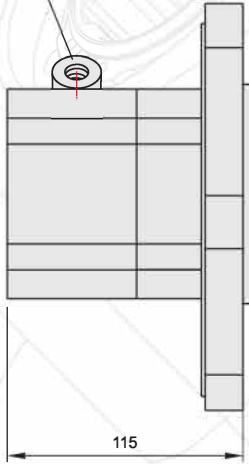

GENEL BİLGİLER/GENERAL DATA

P.T.O. KODU / P.T.O. CODE	50126322	
Tork / Torque	23 Kg _m	255 Nm
Güç(1000 rpm) / Power	16 Hp	12 Kw
Devir / Speed	500 rpm	500 rpm
Oran / Ratio	1/1	1/1
Ağırlık / Weight	11 kg	24,3 lb
Bağlantı / Mounting	Kuyruk	Rear
Kumanda / Control	Havalı	Pneumatic
Dönüş / P.T.O. Rotation	Sağ - ISO	Right - ISO

Ana Şanzıman / Gearbox	Kullanılan Bazı Araçlar / Used Vehicles
G 125-135-155-180-200-210-221-240-255-260	1729-1735-1827-1834-1838-1929-1935-2038-2429-2435-2527-2531-2534-2629-2631-2635-2638-3229-3234-3534-3535-1831-1835-1840-1844-1848-1850-1857-1934-1938-1953-2044-2050-2544-2550-2650-2643-2644-3031-3234-3331-3348-4148-3331-3335-3336-3235-3340-2031-2040-2648-3548-3553-3557-3538
	ACTROS MERCEDES BENZ

Seçeğinizin pompanın dönüş yönü, P.T.O. dönüş yönü ile ters olmalıdır.
The rotation of the chosen pump has to be opposite with the rotation of P.T.O.

P.T.O. montaj edildikten sonra ana şanzıman yağını tamamlayın.
Fill the oil of the gear box after mounting the P.T.O.

ÜRÜN MONTAJ ve PARÇA LİSTESİ
PRODUCT ASSEMBLY and PART LIST

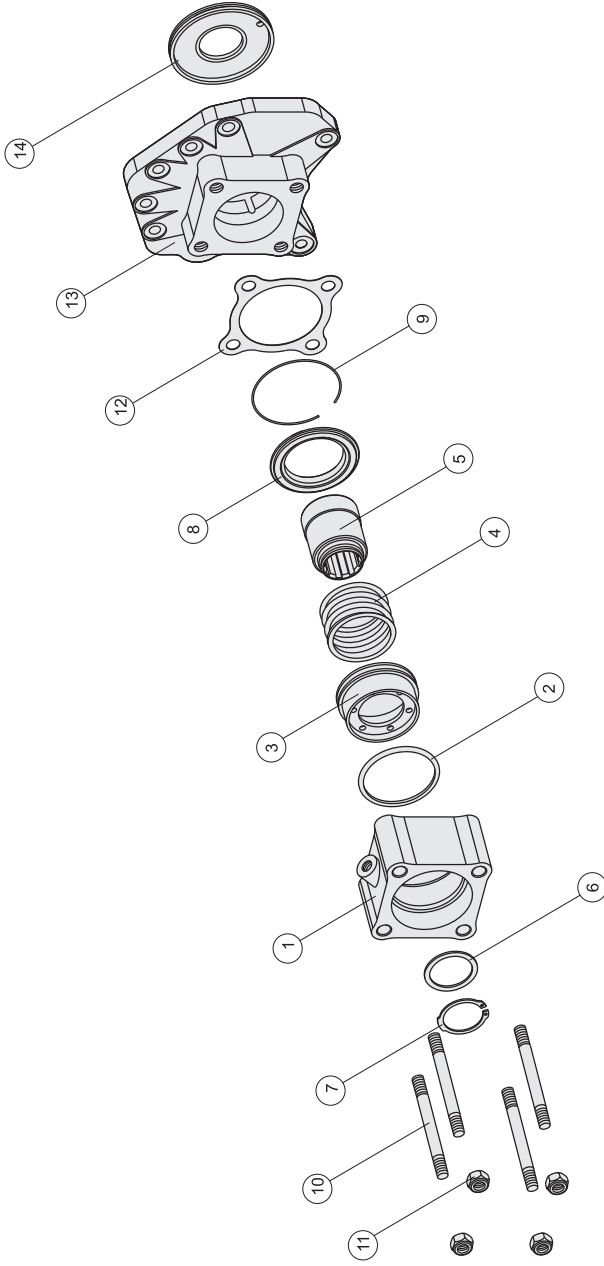

MERCEDES G155-1

Adet	Parça No	Parça Adı	Kod
1	1	Zf1 Gövde	50126322 -01
1	2	69,22x5,33 X-ring	50126322 -02
1	3	Zf1 Piston	50126322 -03
1	4	Zf1 Yav	50126322 -04
1	5	Zf1 Kavrama-45	50126322 -05
1	6	42x52x2 Pul	50126322 -06
1	7	471-42 Segman	50126322 -07
1	8	Zf1 Ortalayıcı pul	50126322 -08
1	9	1.70 Tel Segman	50126322 -09
4	10	M12x120 Saplama	50126322 -10
4	11	M12 Somun	50126322 -11
1	12	Zf1 Conta	50126322 -12
1	13	G155 Plate	50126322 -13
1	14	G155 Alüminyum Plate	50126322 -14
20	TOPLAM PARÇA SAYISI		