

CNC50

monoblock directional control valve
monoblok hidrolik yön kontrol valfi



Index - İçindekiler

Product Features <i>Ürün Özellikleri</i>	14
General Specifications <i>Genel Özellikler</i>	14
Order Coding <i>Sipariş Kodlama</i>	15
Dimensional Data <i>Ölçüsel Bilgi</i>	16
Performance Data <i>Performans Eğrileri</i>	17
Hydraulic Specification <i>Hidrolik Devre</i>	18
Inlet Options <i>Basınç (P) Hattı Opsiyonları</i>	19
Spool Positioners <i>Sürgü Kontrolleri</i>	20
Spool Options <i>Sürgü Tipleri</i>	27
Lever Types <i>Sap Tipleri</i>	29
Outlet Options <i>Tank (T) Hattı Opsiyonları</i>	32

General Specifications

Genel Özellikler

Product Features

CNC50 is an ideal control valve for nominal flow rate 50 lpm and operating pressures up to 350 bar. With its unique design **CNC50** a wide application range.

Accessories

Valve is equipped with an adjustable main relief valve
Available in parallel (in standard) and series circuit
Load Hold Check valve
Wide range of spool options
Interchangeable Ø16 mm Spools
Carry-over and closed center option

Controls

Manual, Pneumatic, Electro- Pneumatic, Hydraulic, Electro-Hydraulic, Solenoid, Inlet Proportional, Mechanical Joystick and Remote Cable Control

Özellikler

CNC50 serisi 50 lt/dk ve 350bar'a kadar maksimum performansı gösteren, gelişmiş özellikleriyle birçok mobil uygulama için ideal kontrol kumandasıdır.

Aksesuarlar

Ayarlanabilir Ana Emniyet Valfi
Paralel Devre ve Seri Devre İmkânı
Yük Tutma Valfi
Çeşitli Sürgü Tipleri
Değiştirilebilir Ø16 mm Sürgüler
Carry-over ve Kapalı Merkez İmkânı

Kontrol

Manuel, Pnömatik, Elektro-Pnömatik, Hidrolik, Elektro-Hidrolik, Direk Elektrik, Giriş Oransal, Mekanik Joystick, Halat Kontrol

Standard Material Specifications Standard Malzeme Özellikleri

High Resistance Cast Iron Body *Döküm Gövde*
Hard Chromium Plated Interchangeable Spools *Sertleştirilmiş Krom Kaplama Sürgüler*
Steel spring caps *Çelik Yay Kapakları*
Aluminium Lever Caps *Alüminyum Sap Kapakları*
NBR Seals *NBR Sızdırmazlık Elemanları*

Working Conditions Çalışma Şartları

Recommended Oil Viscosity Range <i>Önerilen Yağ Viskozite Aralığı</i>	10 cSt to 75 cSt
Recommended Fluid Temperature Range <i>Önerilen Çalışma Sıcaklığı (°C)</i>	-20 to +80
Environmental Temperature Range <i>Önerilen Ortam Sıcaklığı (°C)</i>	-40 to +60
Maximum Contamination Level <i>Maksimum Kirlilik Seviyesi</i>	Class 10 (NAS 1638) 19/16 (ISO 4406)

Technical Specifications Teknik Özellikler

Nominal Flow <i>Debi</i>	50 lpm	13 US gpm
Number of Spools <i>Dilim Sayısı</i>	1 - 7	
Maximum Working Pressure <i>Maksimum Çalışma Basıncı</i>	350 bar 250 bar in Series Circuit	5000 psi 3600 psi in Series Circuit
Maximum Back Pressure <i>Maksimum Tank Hattı Basıncı</i>	30 bar	430 psi
Internal Leakage <i>İç Kaçak Değeri</i>	4 cc - 9 cc (100 Bar; 32 cSt, 40 °C)	0,24 - 0,54 in³/m (1450 psi; 32 cSt, 104°F)

Order Coding

Sipariş Kodlama

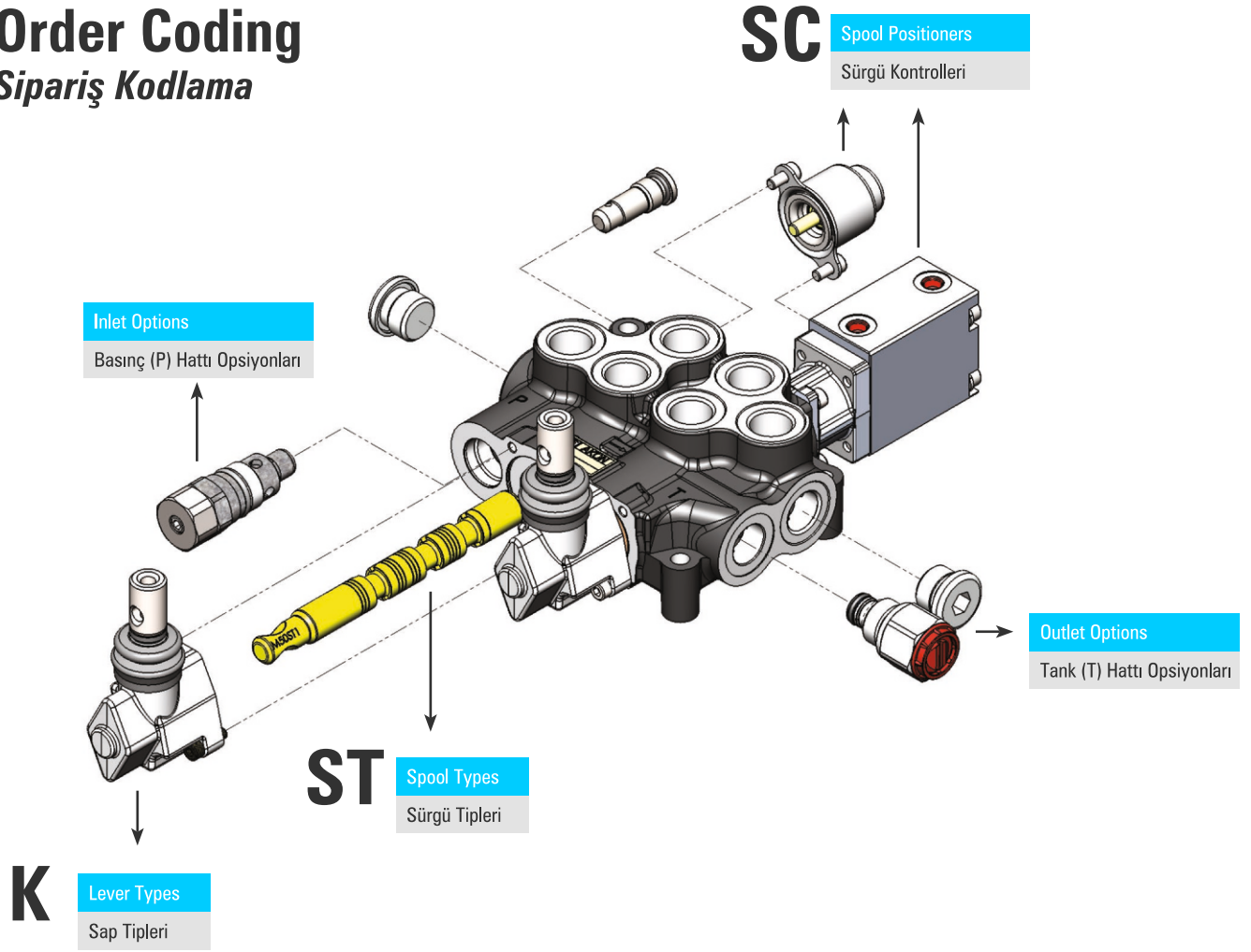

CNC502A - R(180) - SC1 ST11 K1 / SC15 ST1 K1 / H

1 2 3 4

1

Valve Type Valf Tipi

CNC50 Valve Series Valf Serisi
2 Number of Spools Sürgü Sayısı
A Port Thread Port ölçüleri

2

Inlet Options Pompa (P) Hattı Opsiyonları

R Main Relief Valve Ana Emniyet Valfi
180 Pressure Setting Basınç Değeri

3

Working Section Dilim

SC1 Spool Positioners Sürgü Kontrolleri
ST11 Spool Options Sürgü Tipleri
K1 Lever Types Sap Tipleri

4

Outlet Options Tank (T) Hattı Opsiyonları

H Outlet Options Tank Hattı Opsiyonları

This part must be coded separately for each working section. If adjacent sections are identical then code the first section and put number of identical sections with a cross. Example for 3 identical sections; CNC504A-R(180)/SC1ST1/3XSC4ST1

Bu bölümdeki kodlama her dilim için ayrı ayrı yapılmalıdır. Eğer birbirini takip eden ve aynı konfigürasyona sahip dilim isteniyorsa, aynı dilimler, dilim sayısı başa getirilip yanına çarpı konacak şekilde kodlanabilir. Örnek Kodlama; CNC504A-R(180)/SC1ST1/3XSC4ST1

Dimensional Data

Ölçüsel Bilgi

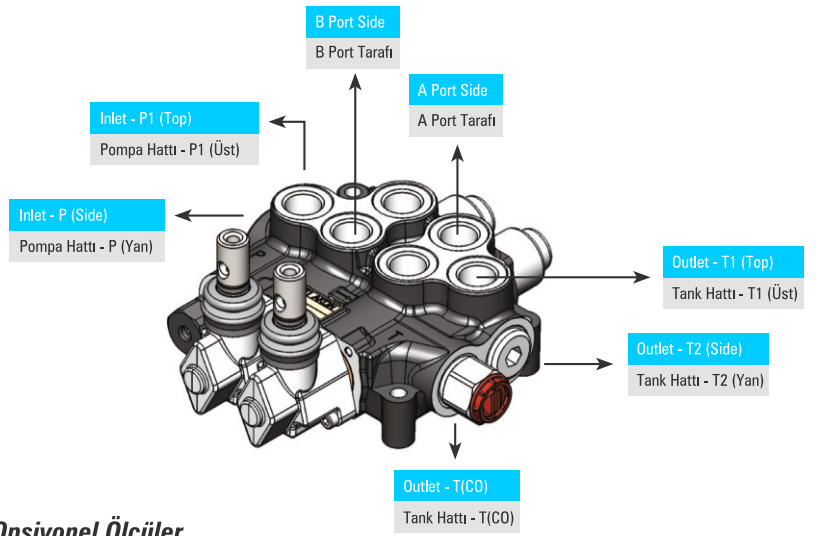

Standard & Optional Threads Standart ve Opsiyonel Ölçüler

Thread	Code	P – P1-T1	A/B	T2	T(CO)
BSP(Standard)	A	G 3/8"	G 3/8"	G 1/2"	G 1/2"
	B	G 1/2"	G 1/2"	G 1/2"	G 1/2"
UN-UNF	L	3/4 - 16 (SAE 8)	3/4 - 16 (SAE 8)	7/8 - 14 (SAE 10)	G 1/2"
	M	7/8 - 14 (SAE 10)	7/8 - 14 (SAE 10)	7/8 - 14 (SAE 10)	G 1/2"
METRIC	U	M18x1,5	M18x1,5	M22x1,5	G 1/2"
	Z	M22x1,5	M22x1,5	M22x1,5	G 1/2"

BSP threads are standard threads. Its necessary to code the port thread after valve series during ordering in monoblock valves. Example coding; CNC502B-R(160)/SC1ST1
Valflerimiz standart olarak BSP Diş üretilmektedir. Talep edilen port ölçülerini monoblok valflerde valf tipi kodlamasından hemen sonra kodlanır. Örnek Kodlama; CNC502B-R(160)/SC1ST1

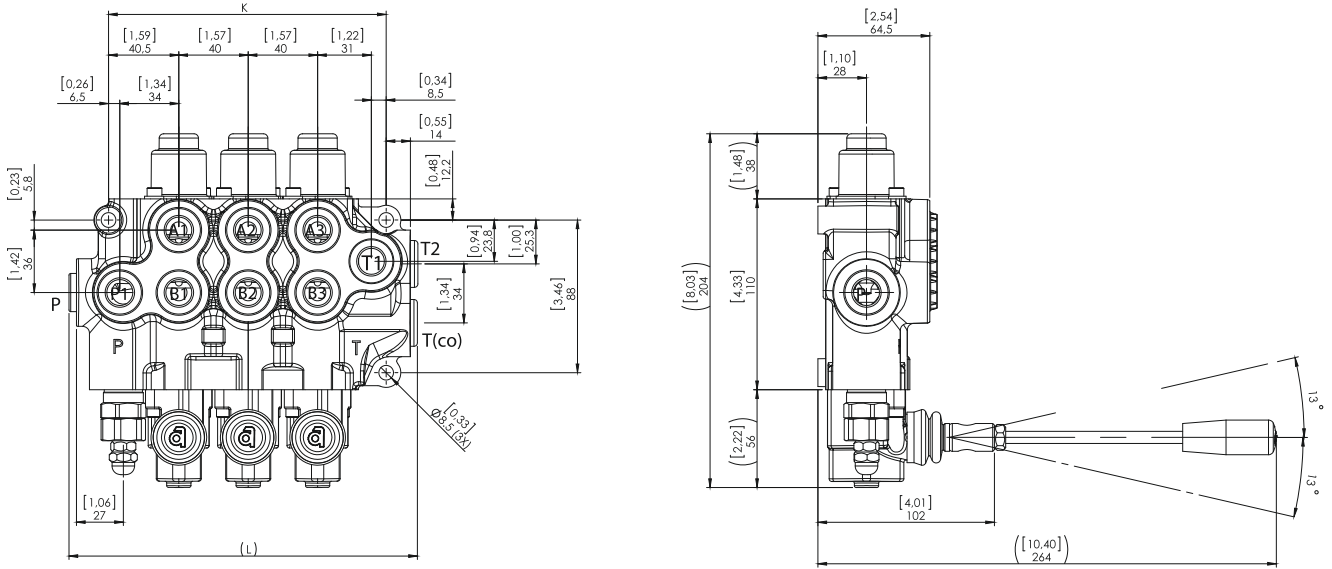

Dimensions & Weight Ölçüler ve Ağırlık

Type / Tip	K		L		Weight Ağırlık	
	mm	inc	mm	inc	kg	lb
CNC501	80	3.15	121	4.76	3.50	7.70
CNC502	120	4.72	161	6.34	5.90	13.00
CNC503	160	6.3	201	7.91	7.15	15.75
CNC504	200	7.87	241	9.49	8.60	18.95
CNC505	240	9.45	281	11.06	10.65	23.50
CNC506	280	11.02	321	12.64	12.30	27.10
CNC507	320	12.6	361	14.21	13.50	29.75

Given weights are for standard configurations.
Ağırlıklar standart konfigürasyon için verilmiştir.

Performance Data

Performans Eğrileri

Pressure Drop Curves Basınç Kayıp Eğrileri

P - T

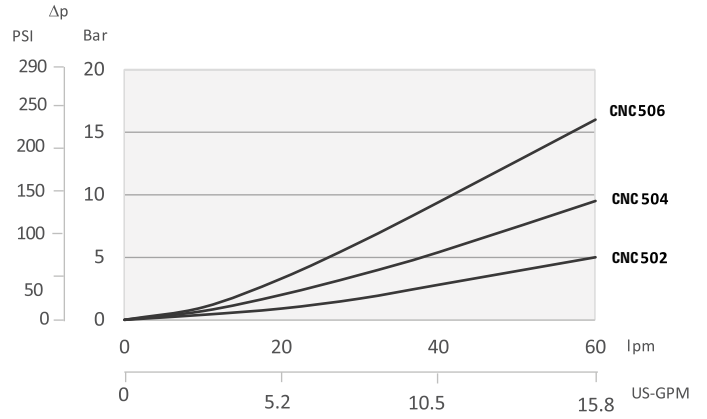
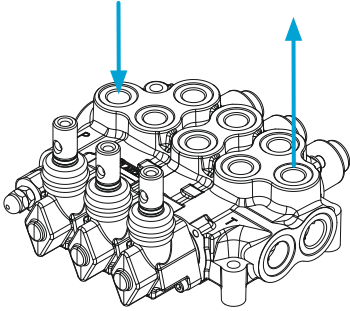

P - A/B

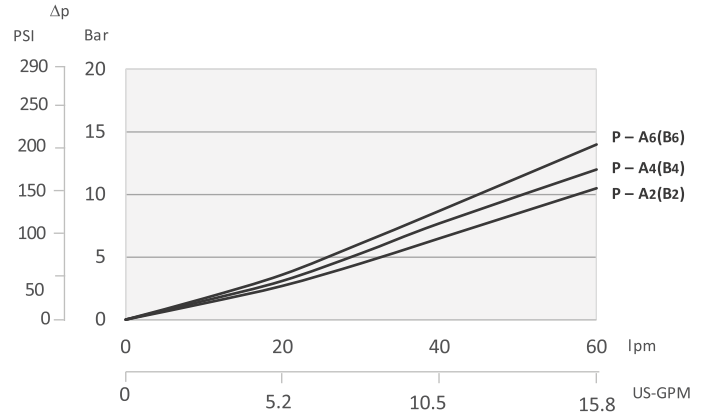
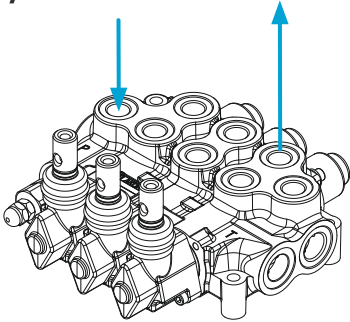

A/B - T

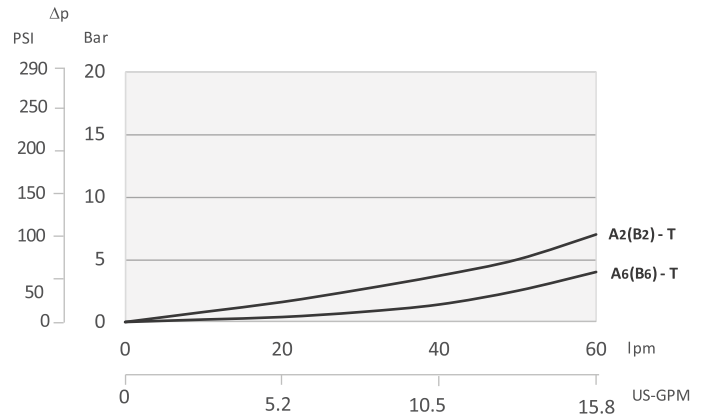
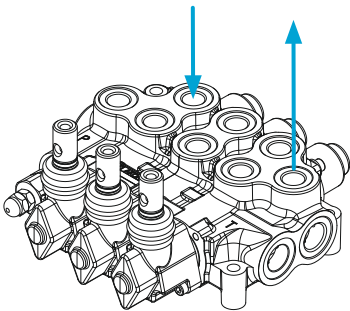

Measured with spool type ST1 and 32 cSt hydraulic oil @ 40°C.
ST1 sürgü ve 32 cSt hidrolik yağ ile 40°C'de ölçülmüştür.

Hydraulic Specifications

Hidrolik Devre

Parallel Circuit *Paralel Devre*

Code / Kod

**NO
CODE**

Standard configuration; Parallel circuit with upper inlet and outlet.
Standart konfigürasyon; Paralel devre, P1 ve T1 açık, P, T2 ve T(CO) kör şeklindedir.

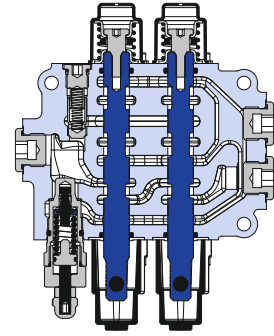
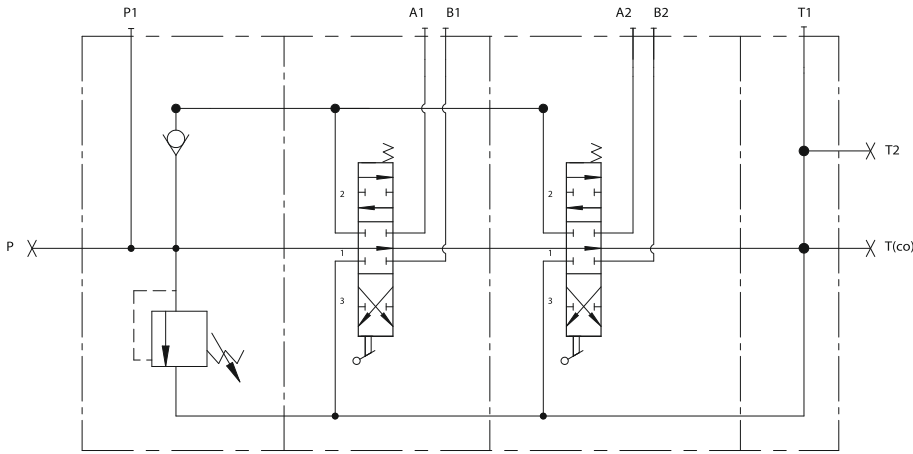

Series Circuit *Seri Devre*

Code / Kod

S

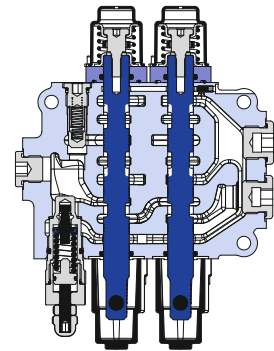
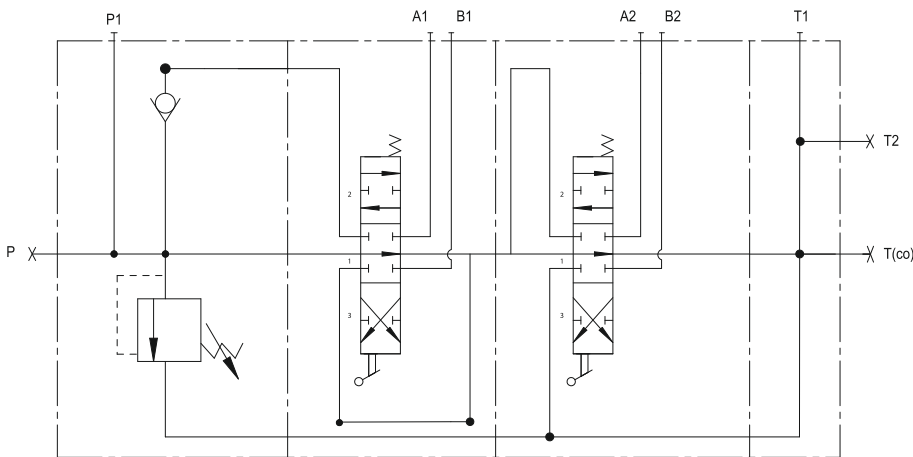

Maximum working pressure is 250 bar.
Maksimum çalışma basıncı 250 bar.

Series Circuit is coded with «S» before each series working section demanded. Example Coding: CNC502A-R(200)/SSC1ST1/SSC1ST1

Seri devre her seri dilimin önüne «S» gelecek şekilde kodlanır. Örnek Kodlama; CNC502A-R(200)/SSC1ST1/SSC1ST1

Inlet Option

Basınç (P) Hattı Opsiyonları

CNC501A - **R(180)** / SC4 ST11 K3 / H

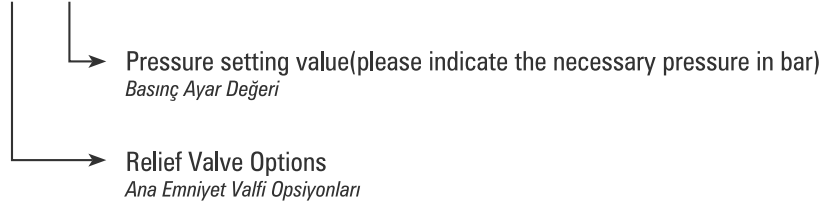

Adjustable Direct Acting Main Relief Valve *Ayarlanabilir Ana Emniyet Valfi (Direk Etkili)*

Code / Kod

R

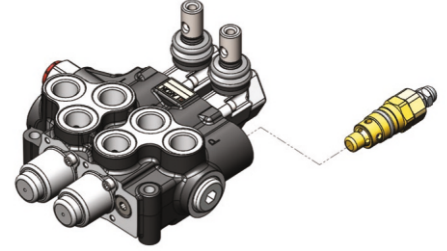
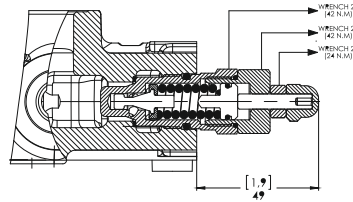
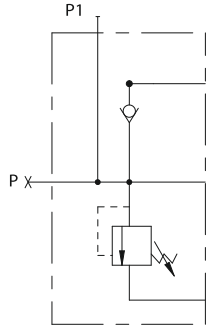

Please indicate the necessary pressure setting value. MRV is preset to 180 Bar at 15 lpm unless otherwise specified.
Lütfen ayarlanmasını istediğiniz basınç değerini bildiriniz. Ürünler standart olarak 15 lt/dk'da 180 Bara ayarlanır.

Main Relief Valve Blanking Plug *Emniyet Valfsiz*

Code / Kod

Y

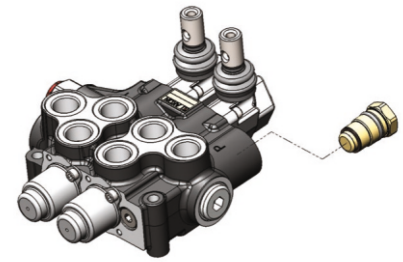
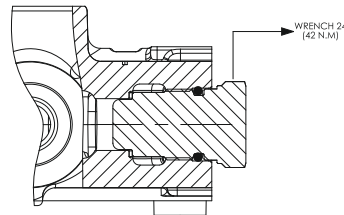
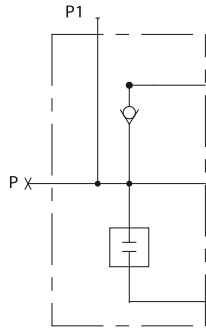

Main Relief Valve Performance Data *Ana Emniyet Valfi Performans Eğrisi*

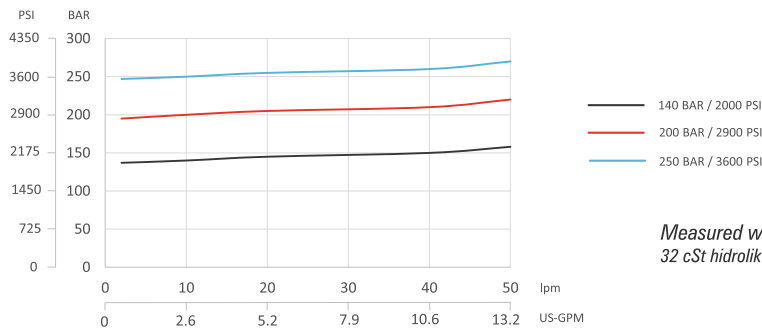

Measured with 32 cSt hydraulic oil @ 40°C and neglected tank line pressure.
32 cSt hidrolik yağ ile 40°C'de, tank hattı basıncı ihmal edilerek ölçülmüştür.

Spool Positioners

Sürgü Kontrolleri

CNC501A - R(180) / **SC4** ST11 K3 / H

Spool Positioners
Sürgü Kontrolleri

Spool Positioners with Spring Return *Yay Dönümlü Sürgü Kontrolleri*

SC1 3 Positions Spring Return

3 Pozisyon Yaylı

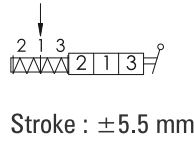
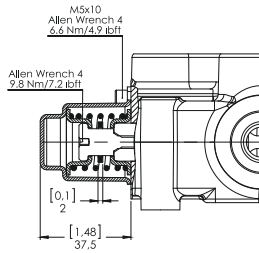

SC5 2 Positions Spring Return

2 Pozisyon Yaylı

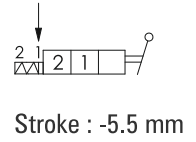
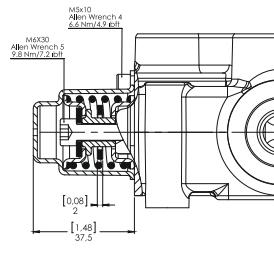

SC6 2 Positions Spring Return

2 Pozisyon Yaylı

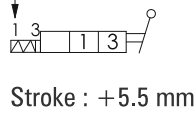
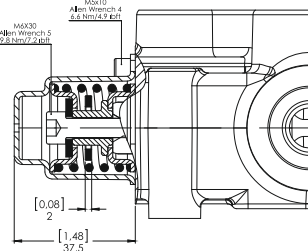

SC11 2 Positions Spring Return in 3rd Position

2 Pozisyon, 3. Pozisyona Yaylı

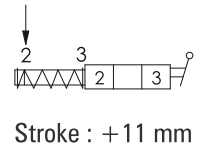
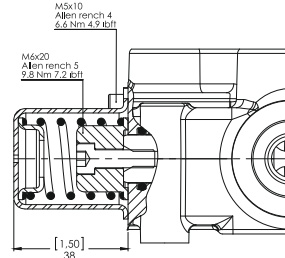

SC25 3 Position Spring Return with male M8 pin extension for dual control

3 Pozisyon Yaylı, M8 Erkek Uzatmalı

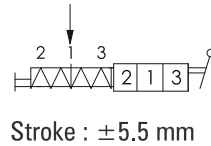
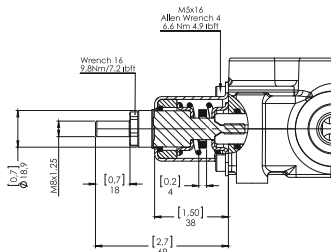

SC12 2 Positions Spring Return in 2nd Position

2 Pozisyon, 2. Pozisyona Yaylı

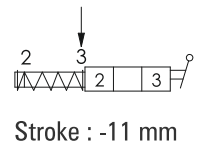
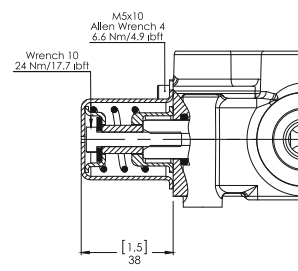

SC33 3 Position Spring Return with stroke limiter

3 Pozisyon Yaylı, Strok Limitleyici

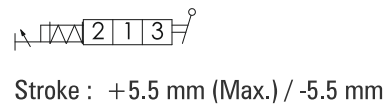
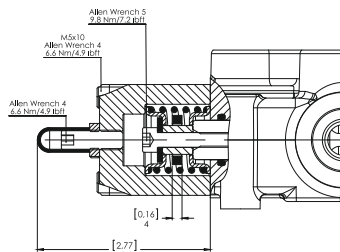

Spool Positioners with Detent *Detantlı Sürgü Kontrolleri*

SC2 3 Position Spring Return, Detent in Pos. 3 3 Pozisyon Yaylı, 3.Pozisyon Detantlı

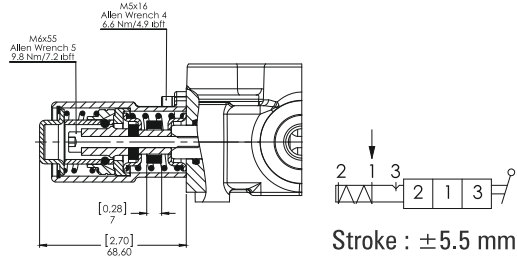

SC3 3 Position Spring Return, Detent in Pos. 2 3 Pozisyon Yaylı, 2.Pozisyon Detantlı

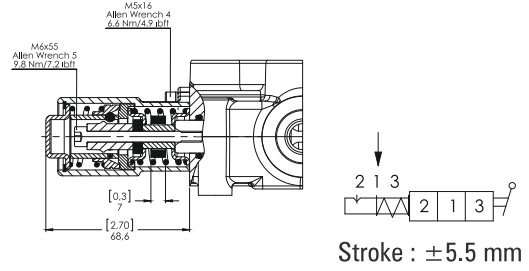

SC4 3 Position Detent in All Positions 3 Pozisyon Detantlı

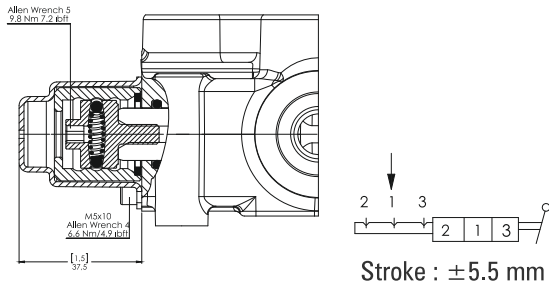

SC7 2 Position Detent 2 Pozisyon Detantlı

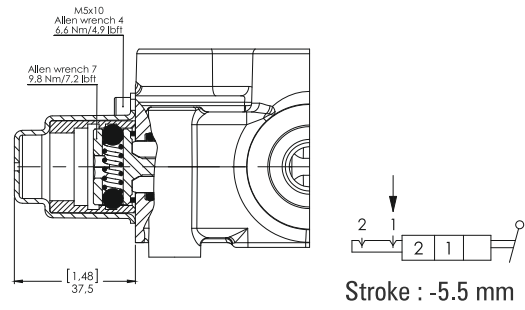

SC8 2 Position Detent 2 Pozisyon Detantlı

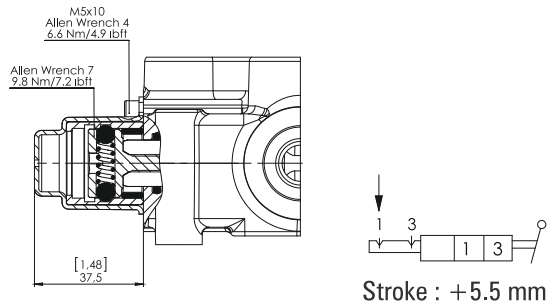

SC13 2 Position Detent 2 Pozisyon Detantlı

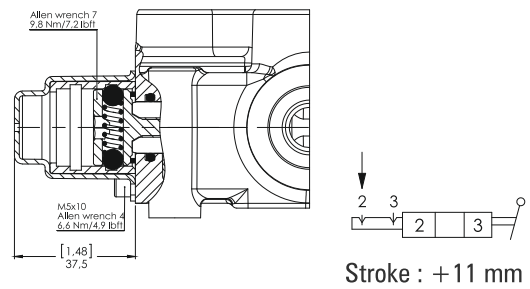

SC28 3 Position Spring Centered with Detent 3 Pozisyon Yaylı ve Detantlı

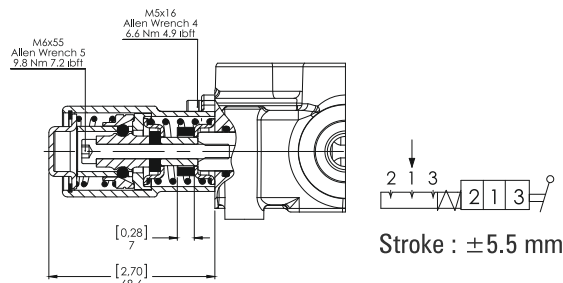

4 Position a Side Spool Positioners 4 Pozisyon A Tarafı Sürgü Kontrolleri

SC9 4 Position Spring Return, Detent in 4th Pos. 4 Pozisyon Yaylı, 4.Pozisyon Detantlı

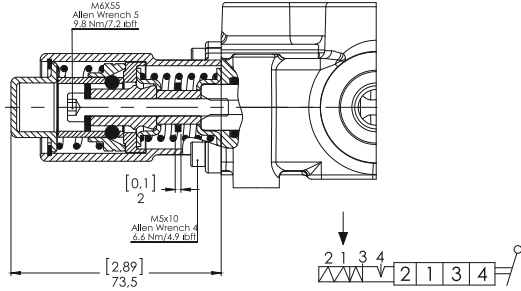

Used with Spool ST9B
ST9B Sürgü ile kullanılır

Stroke : ± 5.5 mm / +5 mm

SC23 4 Position Spring Return, Detent in 4th Pos. 4 Pozisyon Yaylı, 4.Pozisyon Detantlı

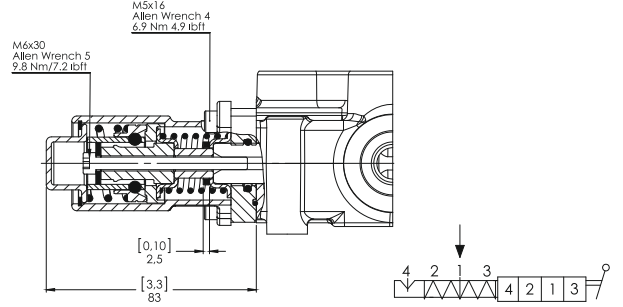

Used with Spool ST9A
ST9A Sürgü ile kullanılır

Stroke : ± 5.5 mm / -4.5 mm

SC10 4 Position Detent in All Positions 4 Pozisyon Tüm Pozisyonlar Detantlı

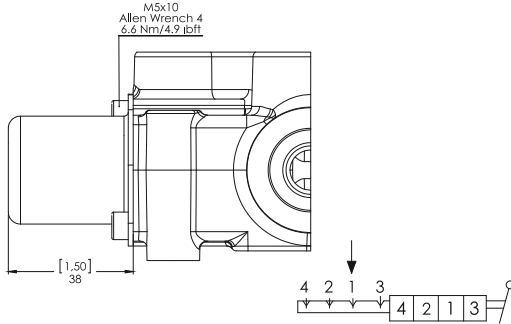

Used with Spool ST9A
ST9A Sürgü ile kullanılır

Stroke : ± 5.5 mm / -5 mm

SC24 4 Position Detent in All Positions 4 Pozisyon Tüm Pozisyonlar Detantlı

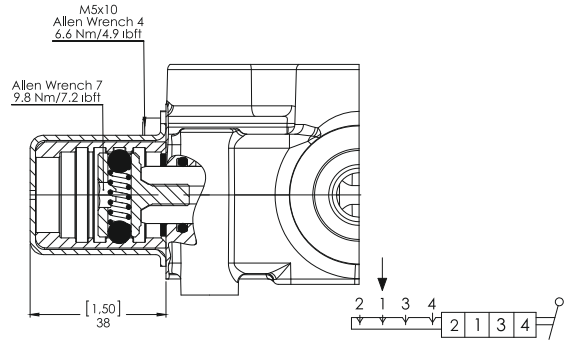

Used with Spool ST9B
ST9B Sürgü ile kullanılır

Stroke : ± 5.5 mm / +5 mm

SC21 4 Position Spring Return, Feel Detent in 4th Pos. 4 Pozisyon Yaylı, 4.Pozisyon Hissetmeli Detantlı

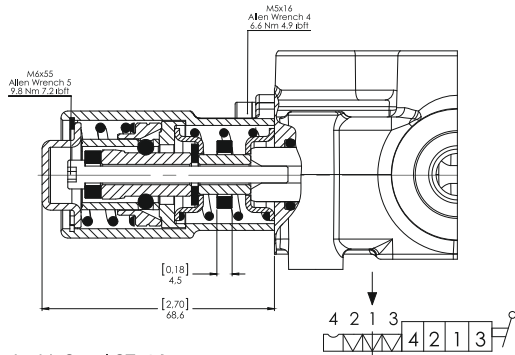

Used with Spool ST10A
ST10A Sürgü ile kullanılır

Stroke : ± 5.5 mm / -3.5 mm

SC22 4 Position Spring Return, Feel Detent in 4th Pos. 4 Pozisyon Yaylı, 4.Pozisyon Hissetmeli Detantlı

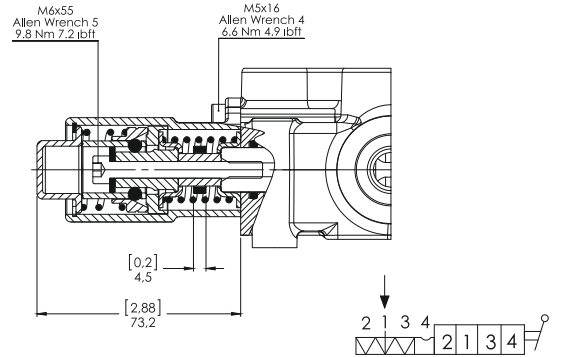

Used with Spool ST10B
ST10B Sürgü ile kullanılır

Stroke : ± 5.5 mm / +3.5 mm

SC15

On-Off Pneumatic Control

On-Off Pnömatik Kontrol

Pilot Pressure
Pilot Basıncı

Min. 6 Bar / 85 PSI
Max. 12 Bar / 170 PSI

Stroke (mm)
Strok (mm)

±5,5 mm

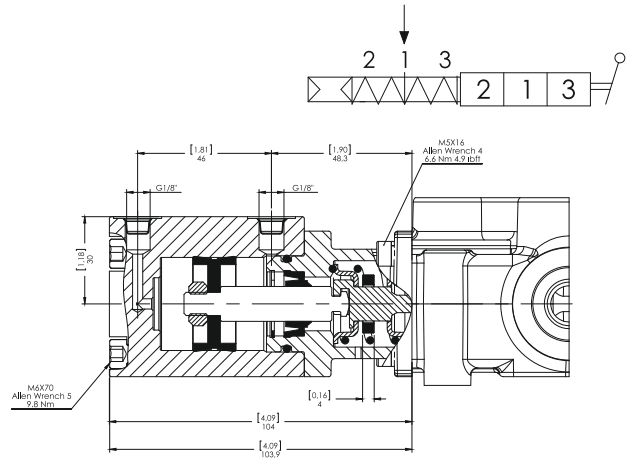

SC30

On-Off Electro-Pneumatic Control

On-Off Elektro-Pnömatik Kontrol

Operation Characteristics Çalışma Özellikleri

Pilot Pressure
Pilot Basıncı

Min. 6 Bar / 85 PSI
Max. 12 Bar / 170 PSI

Coil Characteristics Bobin Özellikleri

Coil Connection Type
Bobin Bağlantı Tipi

DIN 43650

Supply Voltage
Voltaj

12VDC, 24VDC

Protection Type
Koruma

IP65

Nominal Voltage Tolerance
Nominal Voltaj Toleransı

±10%

Duty cycle
Görev Çevrimi

100%

Absorbed Power
Güç

DC 8W

Coil Insulation Class
Yalıtım Sınıfı

Class "H" coil as from
the IEC 85 standard.
Class "H" wire (200° C).

Maximum Temperatures
Maksimum Çalışma Sıcaklığı

Class "F" 155°C
Class "H" 180°C

Stroke (mm)
Strok (mm)

±5,5 mm

Kit Order Code
Kit Sipariş Kodu

12VDC - 2005712000
24VDC - 2005448000

Voltage	Code / Kod
12VDC	SC302
24VDC	SC304

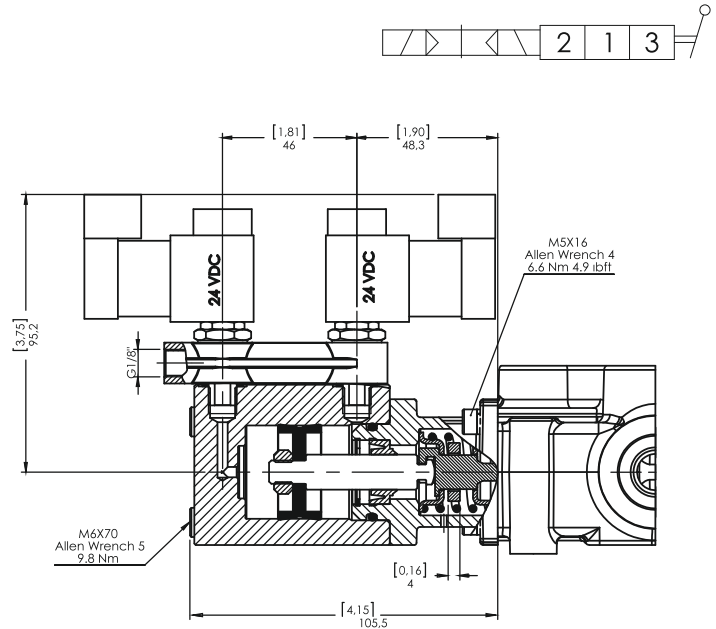

SC16

On-Off Hydraulic Control

On-Off Hidrolik Kontrol

Operation Characteristics Çalışma Özellikleri

Pilot Pressure
Pilot Basıncı

Min. 6 Bar / 85 PSI
Max. 50 Bar / 720 PSI

Stroke (mm)
Strok (mm)

±5,5 mm

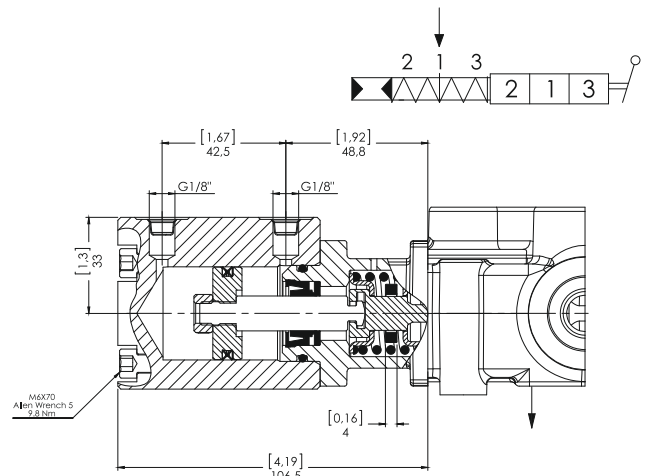

SC17

On-Off Electro-Hydraulic Control

On-Off Elektro-Hidrolik Kontrol

Operation Characteristics Çalışma Özellikleri

Pilot Pressure Pilot Basıncı	Min. 10 Bar / 145 PSI Max. 25 Bar / 360 PSI
Back Pressure Tank Basıncı	Max. 3 Bar

Coil Characteristics Bobin Özellikleri

Coil Connection Type Bobin Bağlantı Tipi	DIN 43650
Supply Voltage Voltaj	12VDC, 24VDC
Protection Type Koruma	IP65
Nominal Voltage Tolerance Nominal Voltaj Toleransı	± 10%
Duty cycle Görev Çevrimi	100%
Absorbed Power Güç	18W
Coil Insulation Class Yalıtım Sınıfı	Class "F" 155°C
Maximum Temperatures Maksimum Çalışma Sıcaklığı	100°C

Stroke (mm) Strok (mm)	± 5,5 mm
---------------------------	----------

Voltage	Code / Kod
12VDC	SC172
24VDC	SC174

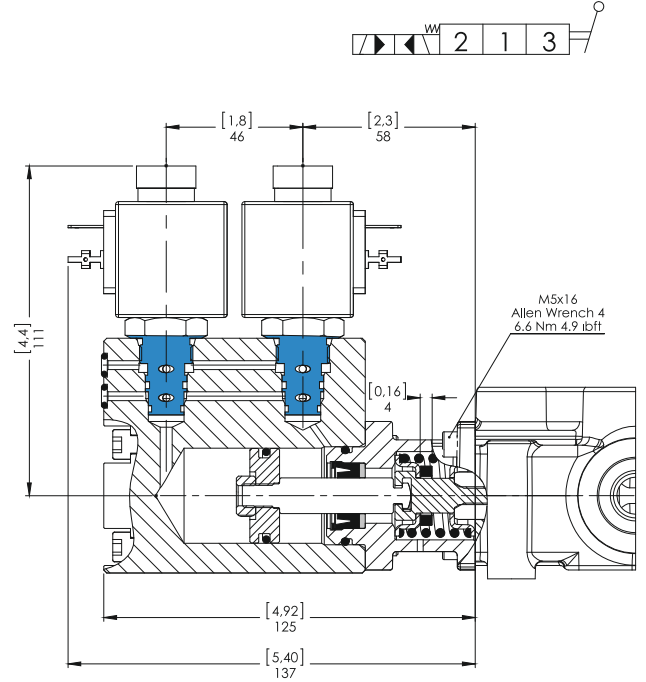

Standard Connection and Hydraulic Circuit Standart Bağlantı ve Hidrolik Devre

Electro-hydraulic kit includes the collector block, pressure reducing valve, back pressure valve and the pipes.
Elektro-hidrolik kiti, dağıtıcı blok, basınç düşürücü, basınç oluşturu ve borulardan oluşur.

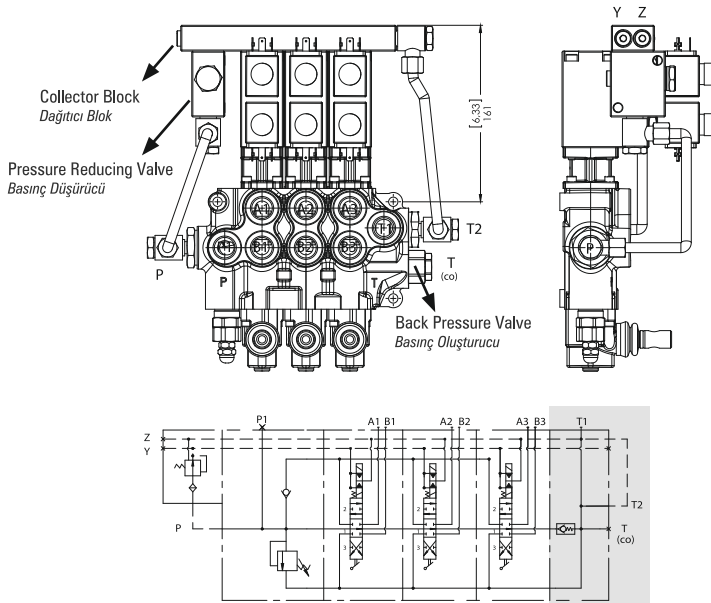

Alternative Connection and Hydraulic Circuit Alternatif Bağlantı ve Hidrolik Devre

Attention!

If tank pressure is more than 3 bar, an external drain line is recommended.
Dikkat!
Sistemde tank basıncı 3 barı geçmesi durumunda sızıntı hattının bağımsız olarak ve direkt tanka bağlanması önerilir.

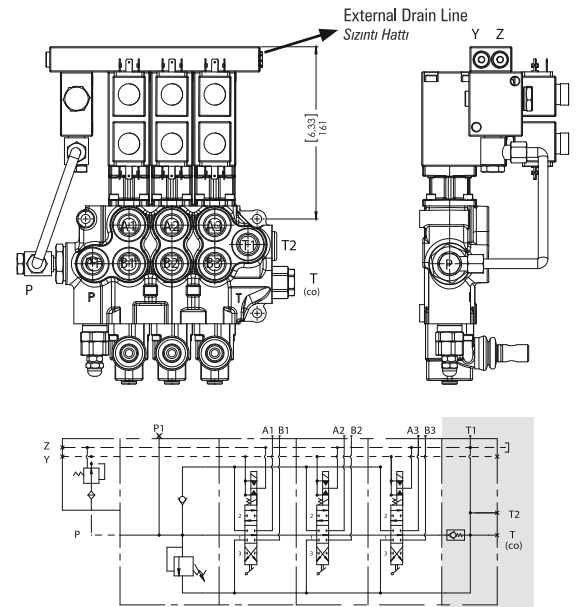

SC14

On-Off Solenoid Control

On-Off Direk Elektrik Kontrol

Voltage

Order Code

12VDC

SC142

24VDC

SC144

Operation Characteristics Çalışma Özellikleri

Working Pressure
Çalışma Basıncı

Max. 230 Bar / 3300 PSI

Back Pressure
Tank Basıncı

Max. 5 Bar / 70 PSI

Internal Leakage
İç Kaçak

Max. 20 cc

Stroke
Strok

± 3 mm

Coil Characteristics Bobin Özellikleri

Coil Connection Type
Bobin Bağlantı Tipi

DIN 43650

Supply Voltage
Voltaj

12VDC, 24VDC

Protection Type
Koruma

IP65

Nominal Voltage Tolerance
Nominal Voltaj Toleransı

± 10%

Duty cycle
Görev Çevrimi

100%

Absorbed Power
Güç

80W

Coil Insulation Class
Yalıtım Sınıfı

Class "H" 155°C

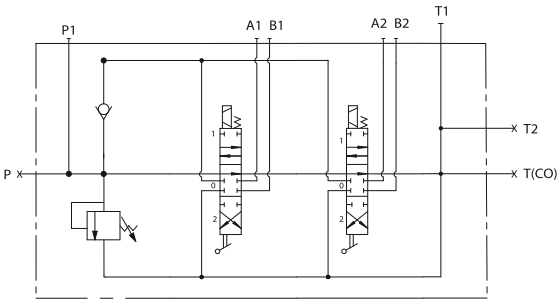
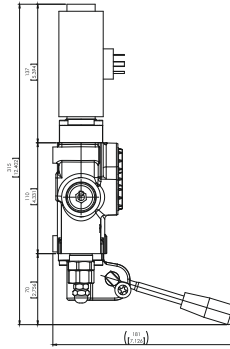
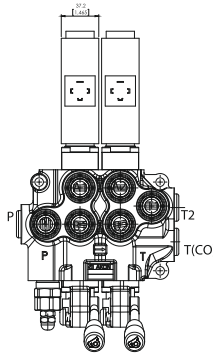
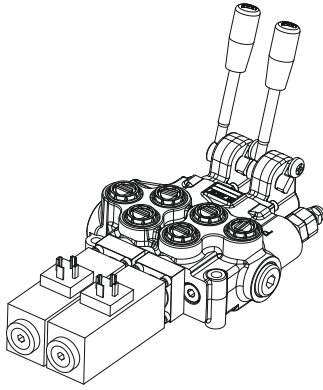
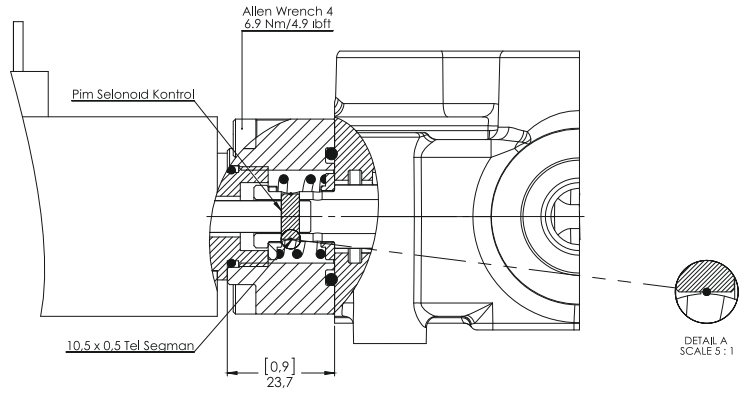
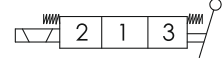

On-Off Direct Solenoid Control requires special machining on valve body, equipped with special lever caps and spools.

On-Off Direk Elektrik Kontrol, özel gövde, sürgü ve sap kapaklarıyla üretilmektedir.

Connection / Bağlantı

Connection / Bağlantı			
	1 - 2	Port B	1 • Negative Pole Negatif Kutup 2 • Spool Out (Pin In) Pin İçerde
	1 - 3	Port A	3 • Spool In (Pin Out) Pin Dışarda 4 • Ground Wire Toprak Hattı

SC18

3 Positions, Microswitch Operation in both positions (NC)

3 Pozisyon, Çift Taraflı Mikrosviç Kontrol (NK)

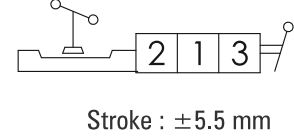
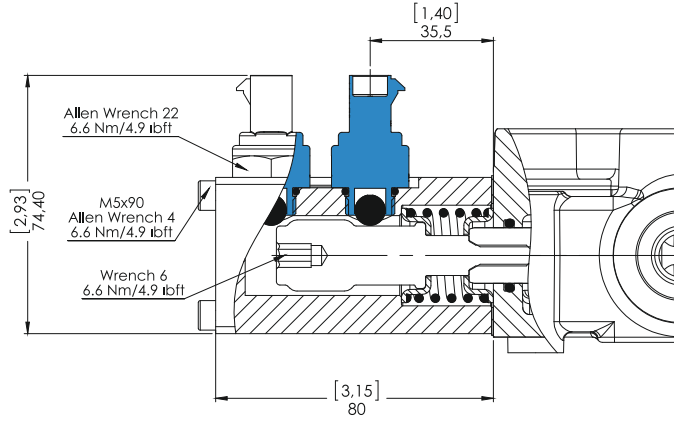

Configuration with normally open (NO) circuit is available, please contact our sales department.
Normalde Açık (NA) konfigürasyon için lütfen satış departmanımızla bağlantıya geçiniz.

SC18A

3 Positions, Microswitch Operation in 3rd Position

3 Pozisyon, 3.Pozisyona Mikrosviç Kontrol

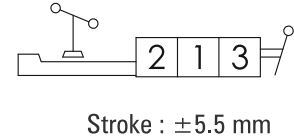
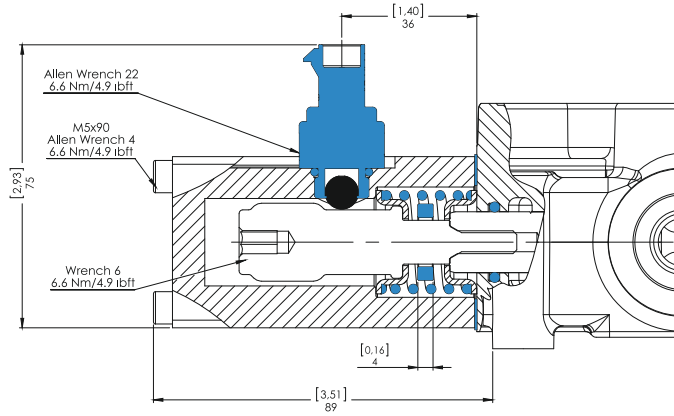

SC18B

3 Positions, Microswitch Operation in 2nd Position

3 Pozisyon, 2.Pozisyona Mikrosviç Kontrol

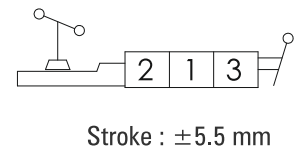
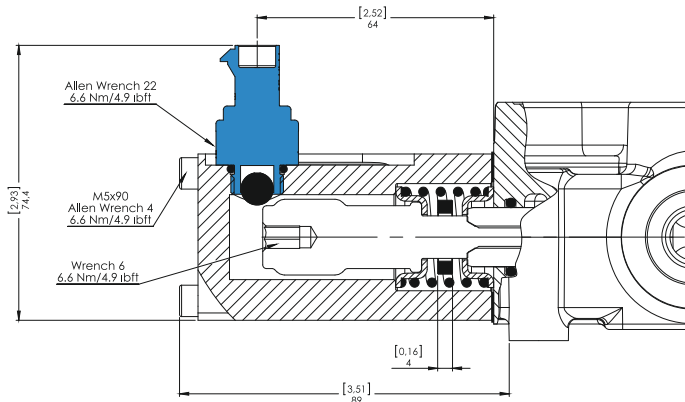

Spool Options

Sürgü Tipleri

CNC501A - R(180) / SC4

ST11 K3 / H

Spool Options
Sürgü Tipleri

Spool Positions Sürgü Pozisyonları

1st Position

1. Pozisyon

Spool Neutral Position
Nötr

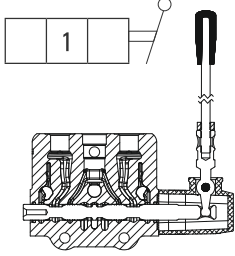

2nd Position

2. Pozisyon

Spool In Position
Mil İçerde

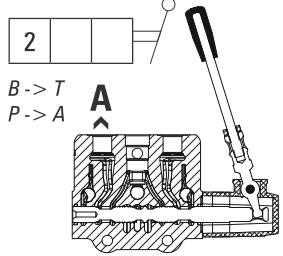

3rd Position

3. Pozisyon

Spool Out Position
Mil Dışarda

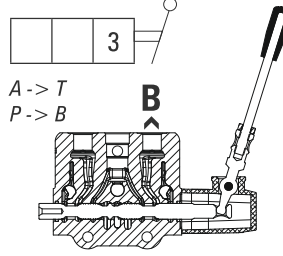

4th Position

4. Pozisyon

4th Pos. Spool Out
4. Pozisyon Mil Dışarda

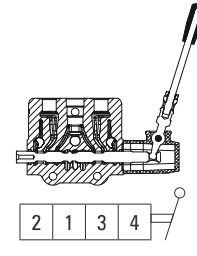

4th Pos. Spool In
4. Pozisyon Mil İçerde

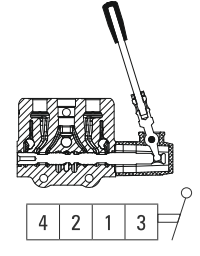

ST1

3 Position, Double Acting

3 Pozisyon, Çift Etkili

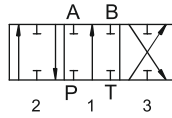

ST4

3 Position, Closed Center

3 Pozisyon, Kapalı Merkez

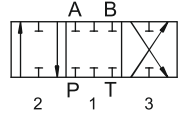

ST2

3 Position, A Port Single Acting

3 Pozisyon, A Port Tek Etkili

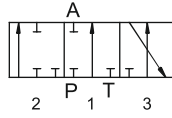

ST5

3 Position, A Port Single Acting and to Tank

3 Pozisyon, A Port Tek Etkili ve Tanka Açık

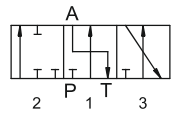

ST3

3 Position, B Port Single Acting

3 Pozisyon, B Port Tek Etkili

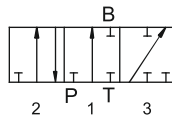

ST6

3 Position, B Port Single Acting and to Tank

3 Pozisyon, B Port Tek Etkili ve Tanka Açık

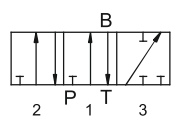

ST11

3 Position, Double Acting, A/B to Tank

3 Pozisyon, Çift Etkili A ve B Tanka Açık

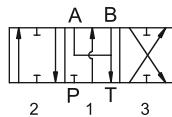

ST7

3 Position, Double Acting A to Tank

3 Pozisyon, Çift Etkili ve A Tanka Açık

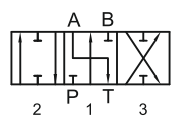

ST8

3 Position,
Double Acting B to Tank

3 Pozisyon,
Çift Etkili ve B Tanka Açık

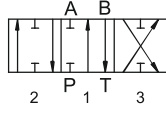

S12A

3 Position, Double Acting With
Regenerative in 3rd Position
(2nd Position Spool In)

3 Pozisyon, Çift Etkili
3. Pozisyonda Rejeneratif
(Mil İçerde 2. Pozisyon)

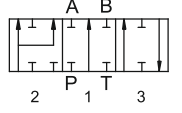

ST9A

4 Position, Double Acting with
Float in 4th Position
(4th Position Spool In)

4 Pozisyon, 4. Pozisyonda Float
(Mil İçerde 4. Pozisyon)

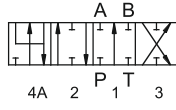

ST12B

3 Position, Double Acting With
Regenerative in 2nd Position
(3rd Position Spool Out)

3 Pozisyon, Çift Etkili
2. Pozisyonda Rejeneratif
(Mil Dışarda 3. Pozisyon)

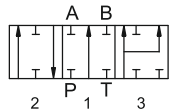

ST9B

4 Position, Double Acting with
Float in 4th Position
(4th Position Spool Out)

4 Pozisyon, 4. Pozisyonda Float
(Mil Dışarda 4. Pozisyon)

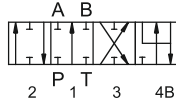

ST19

3 Position, Series Spool

3 Pozisyon, Seri Sürgü

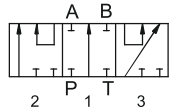

ST10A

4 Position, Double Acting with
Regenerative in 4th Position
(4th Position Spool In)

4 Pozisyon,
4. Pozisyonda Rejeneratif
(Mil İçerde 4. Pozisyon)

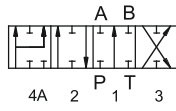

ST10B

4 Position, Double Acting With
Regenerative in 4th Position
(4th Position Spool Out)

4 Pozisyon,
4. Pozisyonda Rejeneratif
(Mil Dışarda 4. Pozisyon)

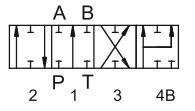

Lever Types

Sap Tipleri

CNC501A - R(180)

/

SC4

ST11

K3

/

H

Lever Types
Sap Tipleri

**NO
CODE**

Standard Lever Kit

Standart Sap Kapağı

2 1 3

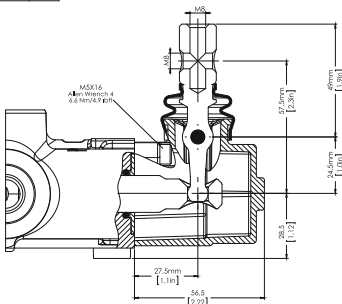

K1

Reverse Lever Kit

Ters montaj Sap Kapağı

2 1 3

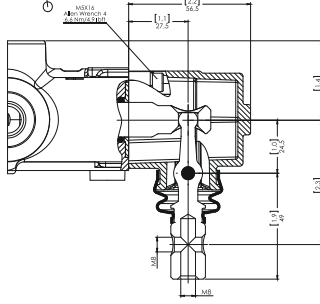

K2

No Lever

Sap Kapaksız

2 1 3

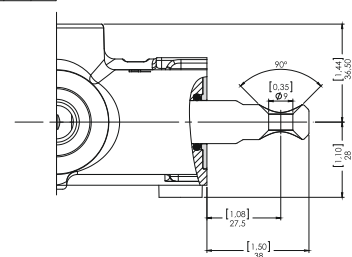

K3

Dust Proof Plate Kit

Toz Kapaklı

2 1 3

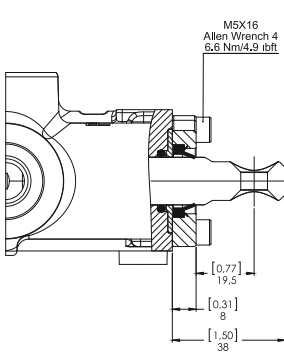

K4

Safety Lever

Güvenlik Kolu

2 1 3

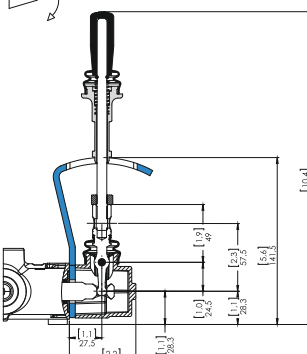

K5

Lever Cap with Spool Limiter

Sürgü Strok Kısıtlayıcı

2 1 3

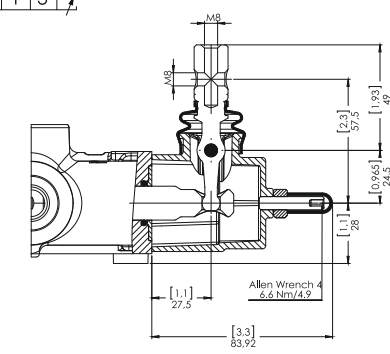

K6

Rev. Lever Cap with Spool Limiter

Ters Montaj Sürgü Strok Kısıtlayıcı

2 1 3

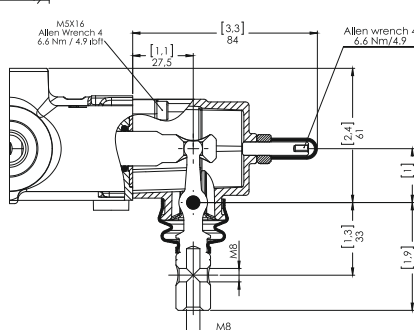

KT

Cable Connection Kit

Kablo Bağlantı Kiti

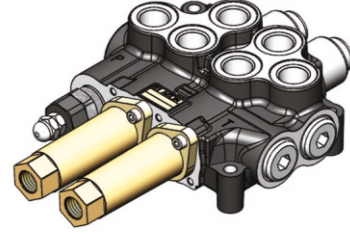
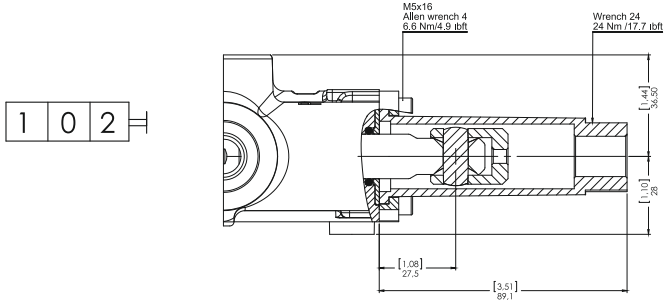

Lever Cable Remote Control Halat Kontrol

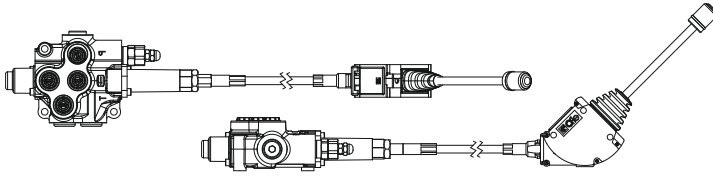

Cable remote control for Group of Levers Halat Kontrol Grubu

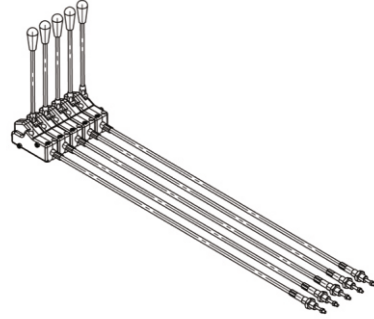

Lever cable remote control and cable remote control for group of levers are modular systems offering unlimited number of levers together through screws, also with many different configurations and cable lengths. Assembled on the valve only on request and extra charge. Please contact our sales department for details.

Halat kontrol ve halat kontrol grubu için farklı uzunlukları mevcuttur. Halat Kontrol grubu ise talebe göre çeşitli dilim sayıları için ve çeşitli uzunluklarda temin edilir. Kontrol grubu birbirine saplamalarla bağlanmaktadır. Lütfen detaylı bilgi için satış departmanımızla bağlantıya geçiniz.

Remote Joystick Control Joystik Halat Kontrol

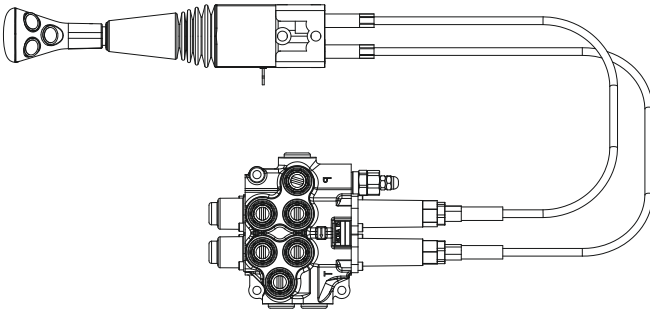

Remote joystick control is available with several options. Please indicate the cable length demanded and contact our sales department for further demands.

Joystik halat kontrol farklı çeşit ve uzunluklarda mevcuttur. Lütfen satış departmanımızla bağlantıya geçiniz.

Joystick Control

Joystik Kontrol

K7

Manual Joystick with pivot on top left

Manuel Joystik Kontrol (Pivot Sol Üst)

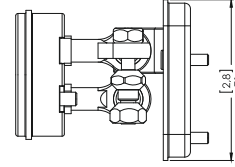
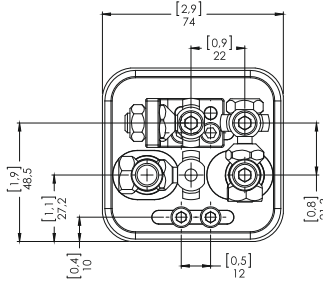
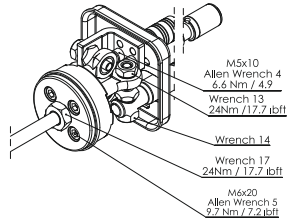
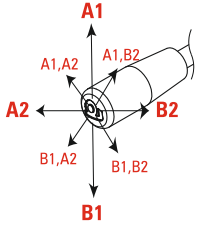

K7 is standard configuration unless otherwise specified.
Aksi belirtilmedikçe K7 standart konfigürasyondur.

K7B

Manual Joystick with pivot on top right

Manuel Joystik Kontrol (Pivot Sağ Üst)

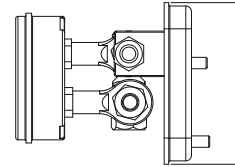
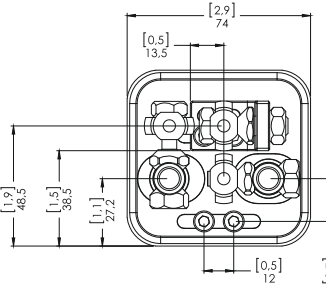
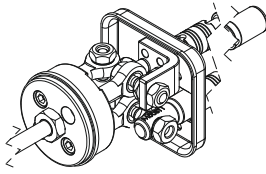
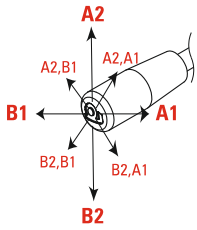

K7C

Manual Joystick with pivot on bottom right

Manuel Joystik Kontrol (Pivot Sağ Alt)

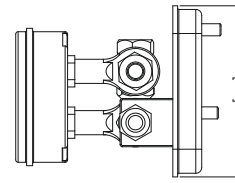
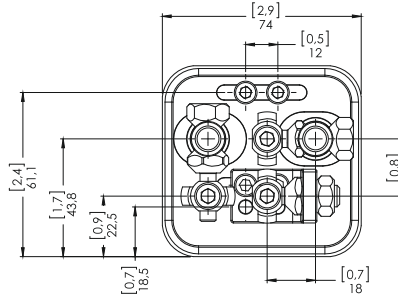
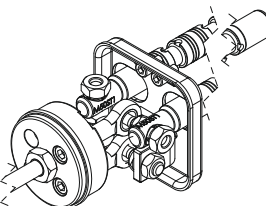
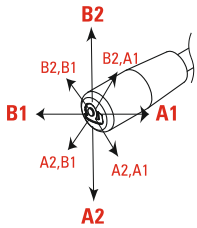

K7D

Manual Joystick with pivot on bottom left

Manuel Joystik Kontrol (Pivot Sol Alt)

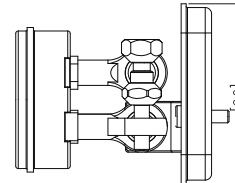
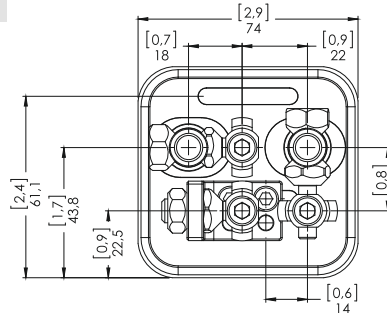
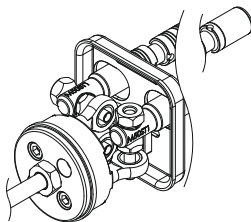
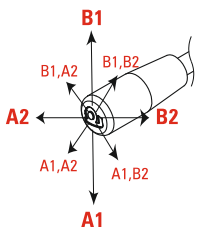

Outlet Options

Tank (T) Hattı Opsiyonları

CNC501A - R(180) / SC4 ST11 K3 / H

Outlet Options
Tank (T) Hattı Opsiyonları

Standard Open Center Upper Outlet (T1 open, T2 and T(CO) plugged)

Standart Açık Merkez (T1 açık, T2 ve T(CO) kör)

Code / Kod
**NO
CODE**

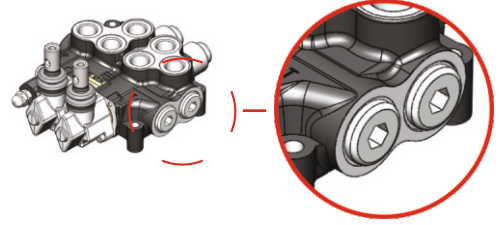
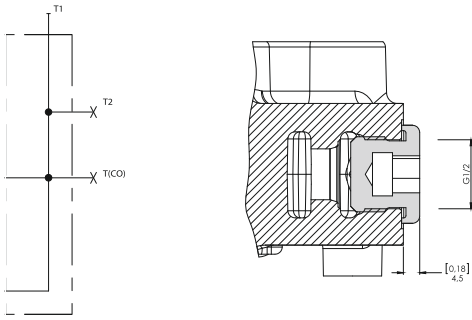

Please contact our sales department for other outlet options.
Özel talepleriniz için lütfen Satış Departmanımızla bağlantıya geçin.

Outlet with Carry-Over

Carry-Over

When Carry-Over is used for series connection with another valve, T1 of the first valve must be connected to the tank.

Carry-over kullanıldığında, 1.valfin tank hattı (T1) mutlaka tanka bağlanmalıdır.

Code / Kod
H

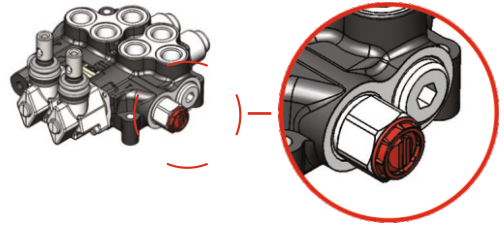
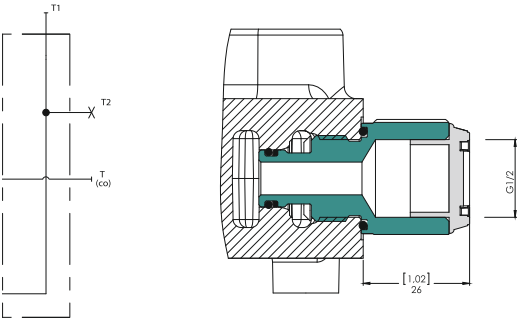

Outlet with Closed Center Plug

Kapalı Merkez

Code / Kod
K

