

Araç Tipi Vehicle Type	HAFIF TİP İTFAİYE ARAÇLARI & YOL BAKIM ARAÇLARI LIGHT DUTY TRUCKS, FOR FIRE FIGHTING VEHICLES & FOR ROAD SERVICE VEHICLES
Şanzıman Tipi Gearbox Type	

Ürün Kodu / Product Code	CNC 400 M
Revizyon No-Tarih / Revision No- Date	

Ürün Görünümleri / Product Views

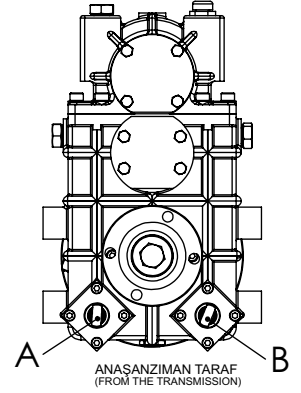
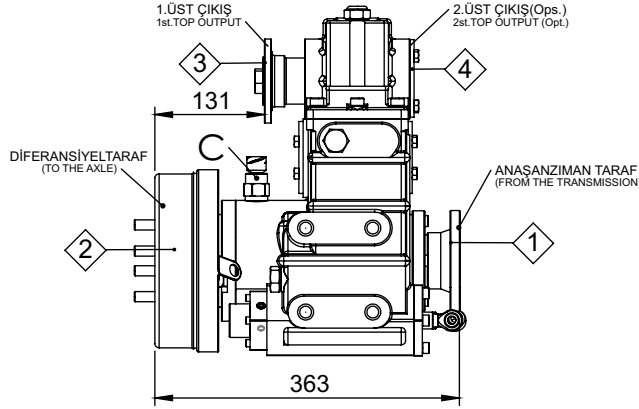
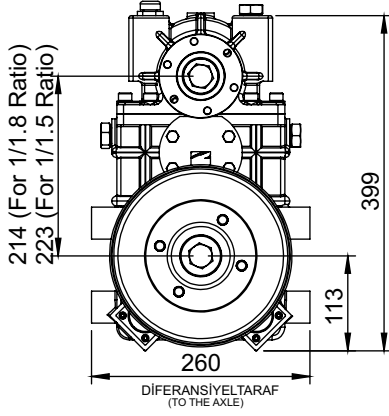

ISO 7647 - ISO 7646 - ISO 8667 Standartlarda Kaplin

ISO 7647 - ISO 7646 - ISO 8667 Standard Flange

Fren Balata Sistemi (Mitsubishi-Hyundai-Isuzu-Hino)

Hand Brake System (Mitsubishi-Hyundai-Isuzu-Hino)

ISO 7647 - ISO 7646 - Standartlarda Kaplin

ISO 7647 - ISO 7646 - Standard Flange

ISO 7647 - ISO 7646 - Standartlarda Kaplin

ISO 7647 - ISO 7646 - Standard Flange

A Mekanik Kolu Çekince Üst Çıkış Devrede

Mekanik Kolu İtince Üst Çıkış Devre Dışı

When you pull the Mechanical Lever, The Top Output is Engaged

When you push the Mechanical Lever, The Top Output is Disengaged

B Mekanik Kolu Çekince Diferansiyel Devre Dışı

Mekanik Kolu İtince Diferansiyel Devrede

When you pull the Mechanical Lever, The Rear Axle Output is Disengaged

When you push the Mechanical Lever, The Rear Axle is Engaged

C Devir Müşiri (Ops.)

Rpm Sensor (Opt.)

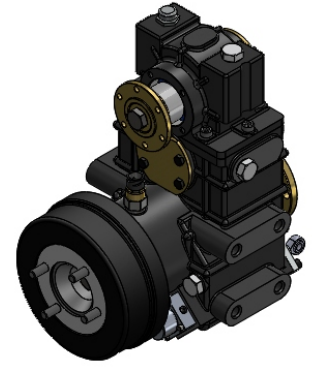

TORK-GÜÇ / TORQUE-POWER

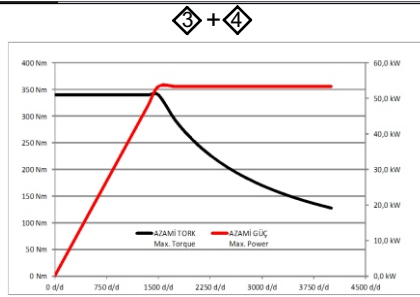
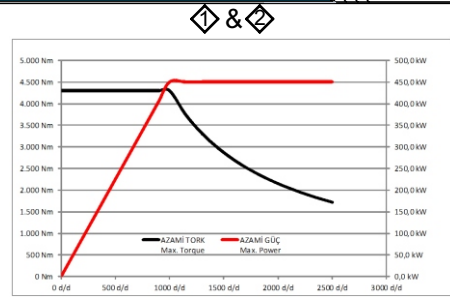

Teknik Bilgi / Technical Data

GİRİŞ/ÇIKIŞ I/O	Azami Tork Maximum Torque (Nm/ Rpm)	Çevrim Oranı (I/O Speed Ratio)	Dönüş Yönü Rotation Sense	Bağlantı Şekli Mounting Type	
1 & 2	4300 Nm	-	-	ŞAFT/SHAFT	- CNC Şirketi katalogta verilen bilgileri önceden bildirmeden değiştirme hakkını saklı tutar. Bu belge genel bilgiler içerir ve taahhüt ve sözleşme niteliğinde değildir. All content contained herein is subject to change without notice. This is not a legally binding document. It is for information only. - Verilen güç ve tork bilgileri sadece PTO/ara şanzımana aittir. Uygulama yapılacak şanzıman, motor ve aracın PTO/ara şanzıman için uygun gördüğü değerleri aşmayınız. Maximum power and torque limits provided are only valid for the mentioned PTO. Do not exceed the PTO power and torque limits determined by the transmission and the vehicle manufacturer. - Şanzımana civata ile bağlanan PTO'lara takılacak pompa, şaft vb. parçaların ağırlık ve askıda kalan uzunlukları şanzıman ve araç üreticisinin onayladığı limitleri geçmemelidir. For PTO's coupled rigidly to the transmissions, supported weight and the length of the attached pump, shaft etc. should not exceed the limits provided by the transmission and the vehicle manufacturer.
3 + 4	340 Nm	1/1.5 1/1.8	Girişle Aynı Yönde Same as input		
5	-	-	-	Gövde Malz. Body material	
				62	