

50510222P0

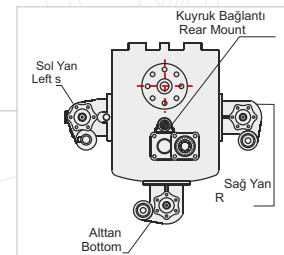
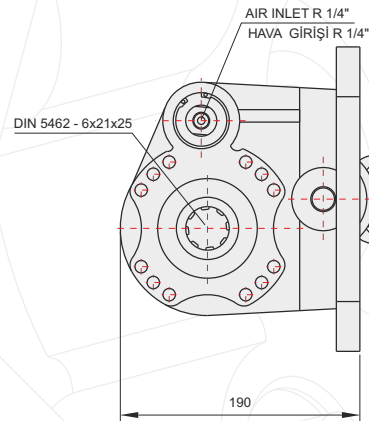
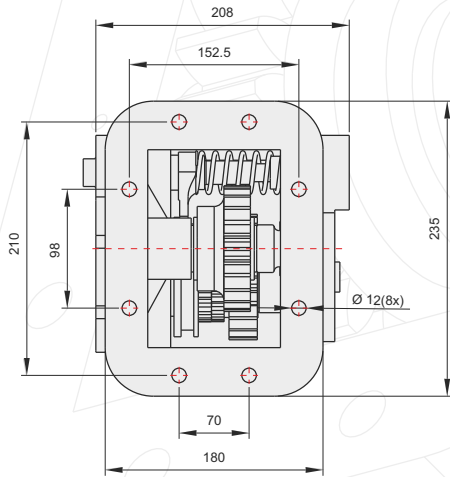
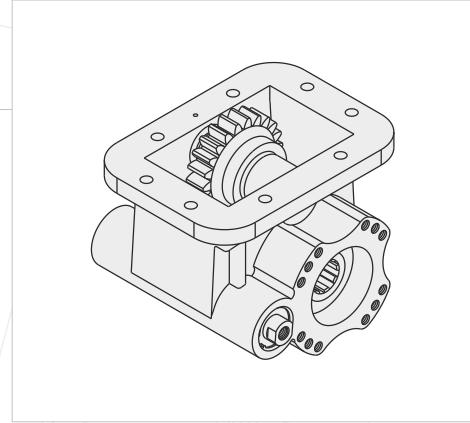

GENEL BİLGİLER/GENERAL DATA

P.T.O. KODU / P.T.O. CODE	50510222P0	
Tork / Torque	40 Kgm	392,4 Nm
Güç(1000 rpm) / Power	57,8 Hp	43,1 Kw
Dev Speed	1050 rpm	1050 rpm
Oran / Rat	1/1	1/1
Ağırlık / We	14 kg	30,9 lb
Bağlantı / Mount	Altan Ç	
Kumanda / Control	Havalı	Pneumat
Dönüş / P.T.O. Rotat	Sağ - ISO	R

Ana Şanzıman / Gearbox	Kullanılan Bazı Araçlar / Used Veh
RT 11609-11613-11709-12709-14609 MRTO / RTX 9509-9513-9710-11509-14613-15613-15615 A/B/H	19.361-26.321-26.240-26.280 MAN 180.24-280.26-190.26-190.30-190.35-190.42-198.38-240.36-330.26-330.30-330.35-380E30
RT16108LL/FTS16108LL	IVECO / 270.26 FATİH BMC DAF 85-2605-2800-2815-3030-3300-3330-3600-4400-ERF E6-E8-E12-EC 14 LEYLAND / FODEN 4000 MAGİRUS / 19.320-30.280 MAN / FIAT 619-697